

---

---

# **Designing Your New Church Sound System**

---

---

## **Taipale Media Systems, Inc.**

1201 Aberdeen Dr. • Allen, TX. 75002

Voice: (888) 547-1727 • FAX: (972) 747-8084

Email: <curt@churchsoundcheck.com>

Web Site: <http://www.churchsoundcheck.com>

**©1999 Taipale Media Systems, Inc. All Rights Reserved.**

Reproduction by any means, in whole or in part, without prior written permission from the publisher is prohibited.  
This material has been prepared exclusively for your church. It is not to be shared with anyone else.

**Designing Your Sound System** is published by:

**Taipale Media Systems, Inc.**

1201 Aberdeen Dr. • Allen, TX. 75002

(972) 747-8083 • [curt@churchsoundcheck.com](mailto:curt@churchsoundcheck.com)

(888) 547-1727 • Fax: (972) 747 8084

**<http://www.churchsoundcheck.com>**

## **We're Excited to Be Working With You!**

Many thanks for contacting TMS about the sound system requirements for your church. The communication of God's Word is very important to us, so much so that the only consulting jobs we accept are those with churches. We've been working specifically with churches since 1981, and we've stayed true to our objective of *Communicating Technical Excellence to the Church* since framing that concept in 1987.

We offer computer-aided sound system design using the EASE (*Electro Acoustic Simulator for Engineers*) software for fast design choices and good documentation of the job. It also allows us to graphically illustrate to you how smoothly our proposed sound system will cover every seat in your sanctuary.

To further investigate the sound system design and the acoustics of your room, we use the companion EARS software to prepare auralizations for specific seats in your sanctuary. An *auralization* is a computer simulation that allows you to actually listen to what it will sound like in a particular seat before the room is even built or before the sound system is installed. All system equalization, balancing and any required signal delay settings will be confirmed with TEF analysis, and your owner's manual will include TEF documentation of the results.

## **Our Background**

I've enclosed a copy of my resume to give you some insight into my background as a musician, as a recording and live sound engineer, as a church staff member, and as a design/build contractor. That diverse background has proven to be a tremendous advantage to me in the consulting work that I do today.

In addition to my work as a consultant we have an active ministry outreach to church technical support team volunteers and staff throughout the world. Our **Soundcheck Magazine web site** carries articles and tips on how to improve the quality in all areas of technical support ministry in the local church, especially audio, video, lighting, and staging. If you'd like to gain even more insight into my perspective on church sound, just read a few of my articles found on this web site. Or grab a copy of the *Yamaha Guide to Sound Systems for Worship*. I wrote three chapters in that book: Chapter 1 – *Why a Church Needs a Sound System*, Chapter 2 – *Where & How to Buy a Sound System*, and Chapter 13 – *Sound System Operation*.

Our **ChurchSoundcheck Discussion Group** is a very active email communication link to hundreds of members in the US and throughout the world. We are constantly amazed to see where some of our members come from. By the way, we heartily recommend that everyone in your tech support team become a member of our discussion group. If someone on your team has a question about, for example, the best way to mic your choir, they'll receive several responses before the day is out. It's a wonderful blessing to be involved with.

## **Our Work Starts With a Simple Questionnaire**

Your technical support needs are unique to your situation. The sound system that will serve those needs and deliver on its promise requires a unique design as well. In order for us to truly understand your needs, our first step is to get to know y'all a little better and gather some basic technical information.

Our approach is to meet with those individuals in your church who have a handle on your sound system needs. That may include representatives from your worship team, the worship leader, music pastor, of course the technical support team, head usher, senior pastor, and the sound committee. We have developed a questionnaire specifically to help those individuals communicate certain details to us. We'll take their comments along with the input we gather in meetings with your committee and start the design based on that information.

In other words, you expect your new sound system to deliver a sound quality that you already hear in your mind. It's up to us to understand those objectives and to then design a system that will live up to those expectations without breaking a sweat and with room to spare. It may take some effort on your part and ours to arrive at a meeting of the minds, but I think you'll agree that it's well worth the effort for both of us to engage in this initial task. And I think you'll find that the process is helpful for your church as well because it forces the team to think things through methodically and possibly even consider issues that they had not yet thought of.

## **Our First Visit to Your Church**

Once we have the results of those questionnaires we would like to attend one of your worship services so that we can experience it firsthand. We have the knowledge, the equipment, the ability and the experience to design a very capable system without ever setting foot in your sanctuary. However if it is possible, we would very much appreciate the opportunity to enjoy one of your worship services for ourselves before we move ahead with the design.

While we are there we will plan to meet with those individuals who shared their input through the questionnaire. It is also very helpful to meet the key members with whom we will be communicating throughout the course of this project. We want to be absolutely certain that we're all headed in the same direction from the start.

If this new sound system is to be installed in an existing facility, then while we're on site we will take some acoustical measurements with our TEF acoustical analyzer. That acoustical data will be very helpful to us as we develop the computer model of your facility and begin the design of the system.

We will need key architectural data in order to develop an accurate acoustical model, so we'll be asking you for a copy of the most current set of architectural drawings along with a DXF computer file of the floorplan.

## **Then You'll Receive a Summary from Us**

Shortly after those initial meetings you can expect to receive a written report from us summarizing all of the decisions that have been made up to this point. In effect we'll describe to you what functions you're asking the sound system to deliver, the level of quality and complexity we heard you ask for, and a rough idea of what we think it's going to take to get there. If the Church needs a rough budget to fit into the overall plan, we'll do our best to provide one at this time.

## **Balancing Technical Excellence with The Budget**

We assume that you've chosen TMS as your consultant on this project because of our reputation for designing first rate sound systems that can be delivered at a reasonable budget, and because you share our belief in the importance of technical excellence in every worship service. So would it surprise you to learn that our preference is to design your sound system without knowing a budget figure up front?

Think about it. Do you really want me to design the sound system you're going to use in your worship services for the next ten to twenty years based on a budget figure that a committee has pre-determined without any knowledge of sound system design? Or do you want us to design a system that precisely matches the needs that you've expressed to us at a level of quality that will bless the Church? This may not be true in your case, but we've seen churches hand down ludicrous budget figures with no understanding or regard for the task itself, and then wonder for years afterwards why they have such miserable sound quality.

Why not do it right the first time? Not long ago we were invited to design a new sound system for a church that I'd wanted to work with for several years. They had a miserable sound system and I'd been praying for the opportunity to design its replacement. Well, that day finally came and as I was visiting with the music pastor – a good friend of ours – he admitted to me that they had made a huge mistake in purchasing their first sound system. They made their decision at that time based on price alone, and had lived with terrible sound for the next eight years until they finally couldn't stand it anymore.

We choose products that we personally would enjoy working on. Working on some really great equipment has spoiled me over my career, and my tendency is to choose the best products I know of. However, I also approach designing a system like it was my money we were spending, and therefore I have a stubbornly practical side of me as well.

If it turns out that the system we have designed is beyond the budget realities that your Church is dealing with, then we'll work with you to "value engineer" it back into line. You should realize that I worked in a church for eight years. I understand firsthand that the audio team isn't the only ministry asking for money.

My job as your consultant is to be your advocate in this process. Part of that task is to explain to you what you're giving up if you delete this or that piece of equipment from the project. Another part of that task is to be sure that the important stuff – like the quality of the main loudspeaker system – isn't diminished in the process. Instead, we'll make changes in the equipment that can be added later on, like better quality microphones, compressors and effects devices, a bigger and better mixing console, and so on.

Arriving at the optimum balance between technical quality and financial stewardship takes experience, and is an area we are totally comfortable in working through with you. As much as it hurts me as a sound engineer to say this, I've worked in enough churches to know that the typical church congregation probably won't hear the difference between a \$60,000 console and a \$16,000 console. I will. Your sound team will! Your musicians will, and a select few staff members or individuals in your Church will. But the average member of your congregation probably won't. So the question comes down to where to invest the money. As your advocate in the process I'll lead you to that point and help you make an informed decision.

We realize that it is important to the church administration to have a budget figure for the sound system as soon as possible because they'll be establishing budgets early on in the building project. At the same time, I'm sure that you would agree with me that choosing an arbitrary budget figure hurts everyone in the long run. Your bringing us onto the project early on will let us help you avoid that problem and approach the sound system side of the project with wisdom. Allowing ample time to prepare a carefully thought-through equipment list now will pay huge dividends later on – every time a microphone is turned on.

### **Designing Your Sound System**

Any sound system design consultant who has been in the business for very long will know within moments of walking into your sanctuary what kind of sound system it's going to require to meet the needs you've expressed. I can stand in a sanctuary and literally hear in my mind what the finished result will sound like, before I pick up a pencil. I can poll through my experience and knowledge of several different products from several different loudspeaker manufacturers and *hear* what each of them would sound like in your auditorium.

As soon as you've contracted TMS to be your consultant, it becomes our task to prove it to you, to the sound contractor who will be installing it, and frankly to ourselves. So as soon as we have your architectural drawings in our hands, we'll set out to build an acoustically accurate computer model of your new sanctuary. And then we'll start trying my ideas for loudspeaker choices.

I started out doing sound system designs the old fashioned way – with a pencil, a ruler, a protractor and a calculator, along with stacks of reference books and equipment literature. I got along fine that way but it sure did take a lot of time! I still have those tools of course, but we've managed to speed up the process quite a bit by using a computer to do the number crunching for us.

Just as with any other computer-aided design package, the data that the software reports back to the user is only as good as the design itself. It doesn't choose a loudspeaker for us, and it doesn't tell us where to place it or how to aim it. What it does offer is immediate feedback on my design choices. If I choose to place a particular loudspeaker at a particular location in your sanctuary, and aim it in a particular way, it will show me what the resulting coverage will be at every seat in the auditorium. If I change the aiming just slightly, it will immediately show me the impact of that change. If I change to a totally different loudspeaker, it will show me the impact of that change instantly. My point is that it requires input from a knowledgeable individual experienced in sound system design done the old fashioned way.

As I mentioned earlier, the computer program we use is called EASE (*Electro Acoustic Simulator for Engineers*). It was developed behind the Iron Curtain by Dr. Wolfgang Ahnert to make acoustical studies of opera houses and music theatres in Germany. After the fall of the Iron Curtain, Harro Heinz brought it to the pro audio market. His company, Renkus-Heinz, is based in Irvine, California, and is one of the foremost loudspeaker manufacturers in the world. When the computer model is built according to the architectural drawings, the accuracy of the EASE software for revealing potential problems with a design is absolutely amazing.

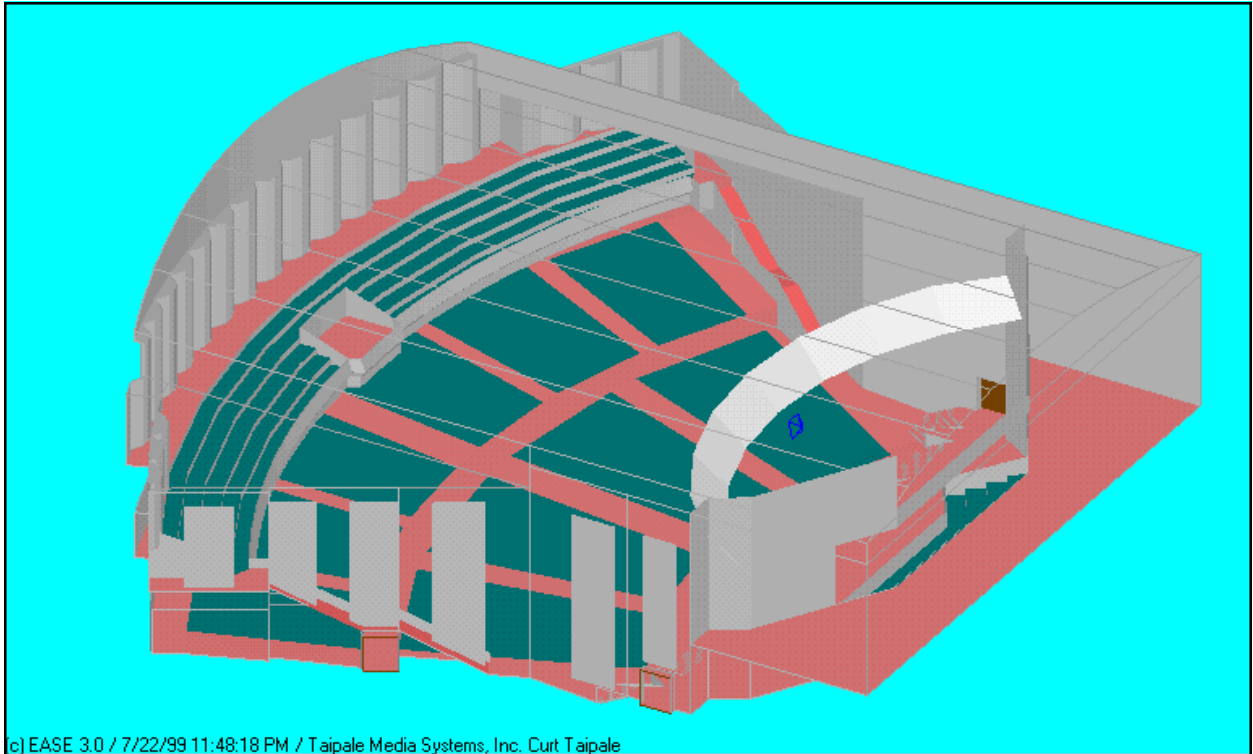

**Figure One**

**Figure One** is simply an EASE wireframe drawing of a church in McDonough, Georgia, but it will give the reader a glimpse of what I'm describing here. The more I've worked with the EASE software in doing sound system designs for churches, the more I've come to trust what it's telling me. Every person who designs sound systems for a living learns something new on every project. We hopefully always affirm that our design approach was the right one, but we usually learn something not to do as well. Anyone who won't admit to that is either not being completely open with you, or they're not being honest with themselves. It's just the nature of the process.

Listening to the installed system do the job I designed it to do is one of the fulfilling moments I have as a consultant. I'll walk the room to check the coverage and take note of any problem areas. Each time I've done a design with EASE and then walked the room listening to the installed system, my system has delivered exactly what EASE showed me it would. The accuracy of the EASE model is remarkable!

That process has taught me to believe what EASE is telling me. There were a handful of times early on in my work with EASE when, if I saw a small problem in the model at some particular seating area, I didn't take the steps to resolve it. The cost to fix that problem didn't seem to be warranted, so I would just "hope" that it wasn't too bad.

But when I walked the installed system, and went over to check that "problem" area, guess what – there it was. I could hear it. And I'd point it out to my client to see if they were interested in spending the additional money on equipment to resolve that issue.

Modeling your auditorium with the EASE software can take anywhere from one long day to several days. It depends on how complex the architecture of your room is. I start with the floor plan and an architectural rule, measuring each point and then transferring that data – point by point – to the computer model.

---

## DESIGNING YOUR NEW SOUND SYSTEM

Can you see why building a computer model might take quite a bit of time? Some of my simplest room models involved around 80 vertices and 60 faces, and yet I've done more architecturally complex sanctuaries that required more like 800 vertices and 600 faces.

Why bother? Yes, it is a lot of tedious work, but I've been taught that any job worth doing is worth doing right, and I won't settle for second best. I've watched other consultants and design/build contractors take short cuts and do designs with more of a "shoot from the hip" approach and that bugs me. I just don't get it. My inner need for perfection won't give me peace in using that kind of approach. In fact I coined an acronym to describe that philosophy and included it in one of my chapters of that Yamaha book: *the LAR factor* refers to the individual who uses the *Looks About Right* approach to sound system design.

Developing an acoustical model of a church sanctuary combines art with science. There comes a point where excruciating detail won't yield any significant improvement in the accuracy of the model, and yet that extra detail will require significantly longer calculation times in later post processing of the data. After working with EASE since 1993 and doing well over 100 acoustical models, I've learned when to draw that line.

### What EASE Will Show Us

I mentioned earlier that we will use the EASE models to graphically illustrate to you the capabilities of the sound system we have designed for you. One of the most important issues for churches is for the sound system to have a smooth coverage over all of the seats in their facility. Well of course it is! So many churches have sound systems that deliver such poor coverage that they begin to wonder if it's even possible. Yes it's possible! And we can prove it to you. Take a look at this:

**Figure Two** is an EASE graphic showing the coverage of one of our sound systems. In fact this one is in that same church sanctuary you saw in Figure One. You're looking at the floorplan of the sanctuary, with the main

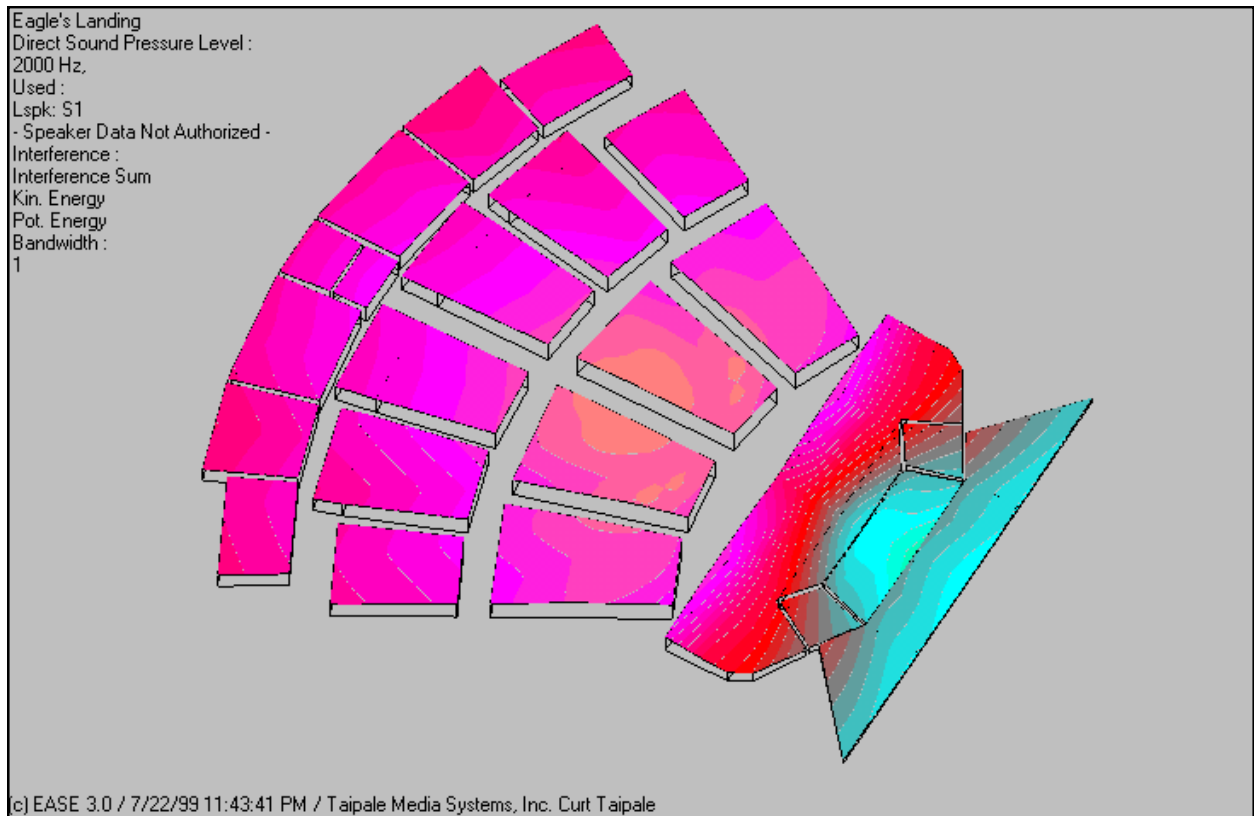

**Figure Two**

seating areas in the middle, and the upper balcony seating areas offset above that. The main stage and drama platform are shown at the bottom right of the graphic. The balcony in this church does hang over the main seating area by a few feet, so I've offset the graphic to show the coverage more clearly. This graphic shows the coverage at 2 kHz. We can choose to examine the coverage at twenty-one different frequency centers from 100 Hz to 10 kHz.

The colors are an indication of how loud the sound could get if the system is operated at full volume. By the way, the coverage you're looking at only takes into account the *Direct Sound* from the loudspeakers. By comparison, we can also view the *Total Sound* (**Figure Three**), which includes the direct sound as well as the reverberation in the room. The *Direct Sound* coverage maps are a bit scary to look at because they show exactly how the loudspeakers interact in the room at those frequencies. They also show what we would measure with a highly accurate tool like the TEF analyzer. The *Total Sound* map is more like what a person would hear in the room, and what would be measured with a Real Time Analyzer. But from a design standpoint, the Direct Sound is more descriptive. It will quickly reveal any problems with the design, as compared with displaying the Total Sound which can easily hide those problems.

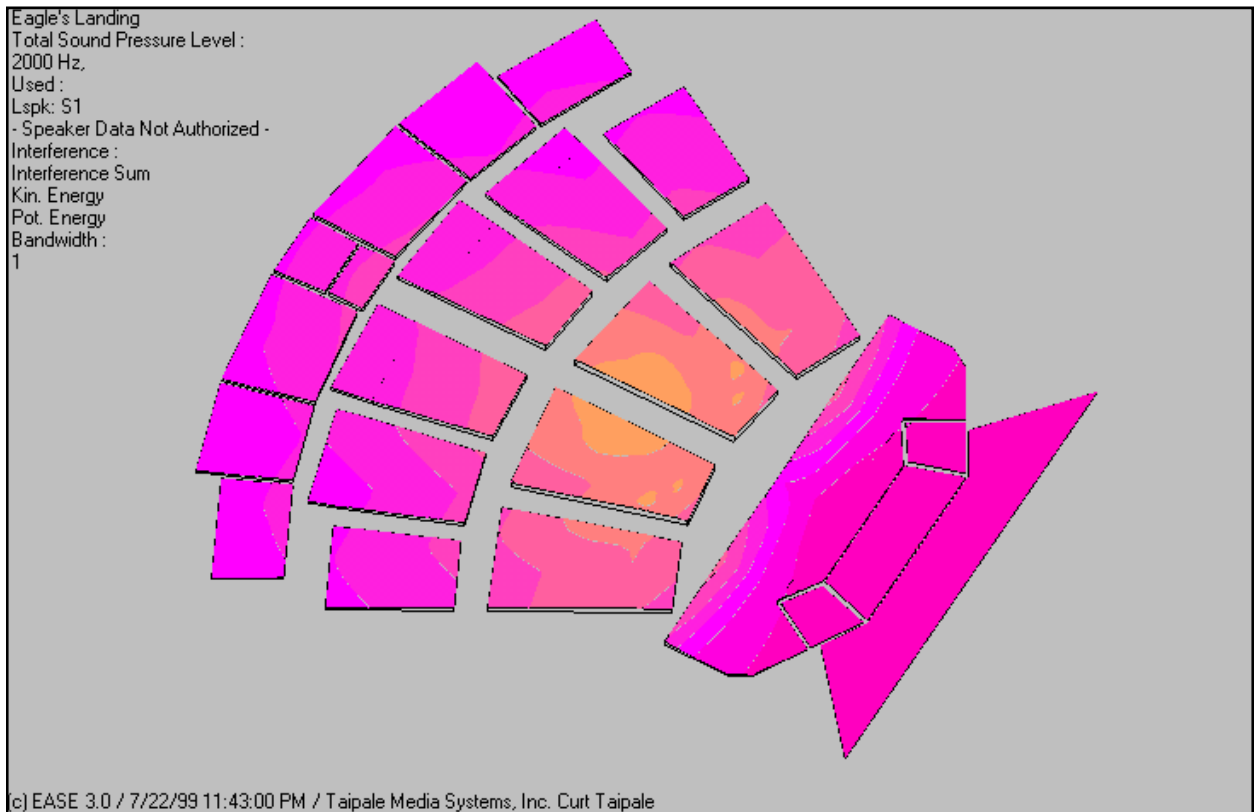

**Figure Three**

We can also examine the predicted intelligibility of the system by looking at the *Articulation Loss of Consonants* (%AL<sub>CONS</sub>). In the US, the statistically most important frequency to consider for speech intelligibility of a loudspeaker system is 2 kHz. Interestingly, in Europe they do intelligibility analysis at 1 kHz. A room with a %AL<sub>CONS</sub> rating of 1% or 2% is considered to have excellent intelligibility. At a value of 15% or higher, communication would be considered unintelligible. Have you ever been in a large, highly reverberant gymnasium, maybe even with the HVAC system running, and had trouble understanding what a friend of yours was trying to say standing just a few feet away from you? That auditorium had a poor %AL<sub>CONS</sub> rating.

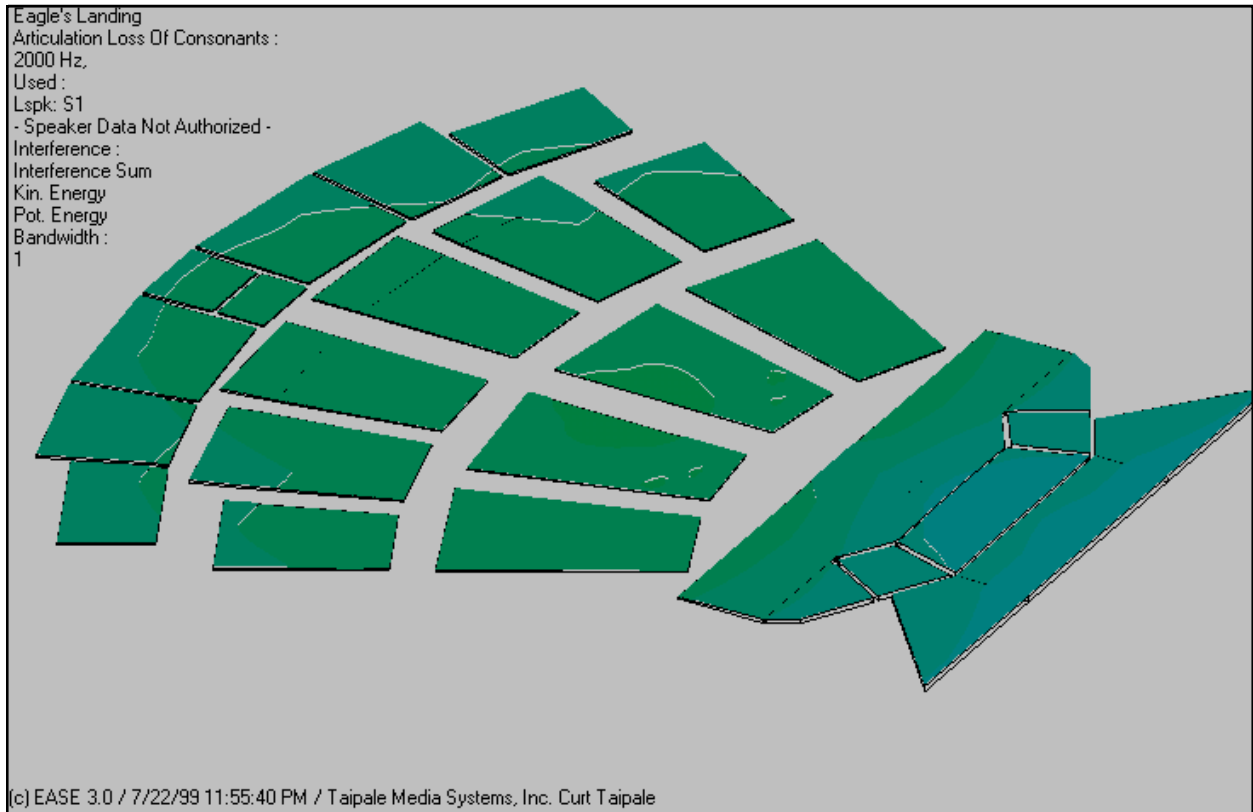

**Figure Four**

**Figure Four** shows the expected intelligibility (%AL<sub>CONS</sub>) for this example sanctuary. There are additional factors to be considered beyond just the sound system, such as ambient noise, and we take those issues into account during our design phase – in part by considering the Articulation Loss of Consonants.

It should be apparent from this conversation that choosing the right loudspeaker for the job involves more than simple preferences for Brand X loudspeakers over Brand Y. It may turn out that Brand Z is actually the optimum choice, and our analysis will quickly lead us to the appropriate solution.

I don't want to mislead you. As I mentioned earlier we have literally hundreds of loudspeakers in our database, and I'm certainly not going to waste your money trying every possible variable in your design. The process does require firsthand knowledge and experience with a wide range of devices, and we work hard at staying in touch with manufacturers and listening to loudspeakers that are appropriate choices for our clients.

One thing you'll find about TMS is that we're very flexible – almost to a fault. If your Senior Pastor or sound committee has expressed an interest in a particular loudspeaker or manufacturer, we'll be delighted to include it in our design. We are confident in our abilities as a design firm, so requests like that don't bother us in the least. After all, our analysis may narrow the choices down to a handful of loudspeakers that appear to perform very well, suggesting that any one of them could be used with excellent results. If one of those loudspeakers is on your short list of preferred devices, we'll certainly take that into account.

Hopefully this description of the EASE software gives you a better idea of the capabilities of the software, and what that means to your project. You'll know what to expect before the sound contractor hangs the first loudspeaker. And the insight I've revealed to you here is just the beginning. There are far more powerful tools built into the software that I use on a regular basis to ensure the accuracy of my designs – of your design.

### Other Issues to Consider

- We will be working with your architect throughout the project to ensure that the acoustics of the space are conducive to a good worship experience, and that the loudspeaker system is attractively implemented.
- We will prepare a list of electrical specifications and then work with your electrical contractor to be sure that the system has clean AC power, and that the appropriate conduit runs are made.
- Of course my background as a musician means that I will be especially careful to design a stage monitor system that your musicians will enjoy working with. And my experience as a live sound engineer will prompt me to be sure that the stage monitor system does not spill unnecessarily into the main congregation seating which would degrade the sound in those areas.
- We will document the system and develop a specification which can then be sent out to capable sound contractors for bid. We will also help you find that contractor to install the system, and then work closely with that contractor throughout the installation to ensure that the system is installed as we intended.
- Finally, if the Church prefers, we can oversee your in-house volunteers as they do the installation themselves. There are a number of issues to consider in this regard, and such a project should not be taken on without the conviction to see it through. But such a process can save the Church a considerable amount of money overall, so if that is your preference please don't hesitate to ask. We'll give you an idea of what is involved in such an endeavor, and help you determine if your church volunteers can finish the task successfully.

If this is the approach that you prefer to take, please rest in the knowledge that it *can* be done. Every church we have worked with that wanted to do the installation themselves now has a successfully installed sound system to enjoy. They know where every scrap of wire goes, they know exactly how the system is put together, and that bolsters their confidence in its operation. One strong side benefit of this approach is that your team will *take ownership* of the system more quickly than they would if someone else does the install and just hands you the keys.

### Backing Up Our Claims

We know that you're going to enjoy listening to the final results of your new sound system. Still the job wouldn't be complete without offering you proof that we've done what we said we would. And frankly, we want to be sure that our system has been installed as we intended. So once the system is installed and operating we will confirm that the sound contractor has done the work properly, and then voice the system.

The *voicing* process involves balancing the loudspeaker system(s) for uniform loudness, setting any required signal delays, and adjusting the system equalizer for a smooth system response using our TEF acoustical analyzer. Upon my return from this trip we will provide you with TEF documentation of the results.

We use both *TEF* and *Smaart Pro* for acoustical analysis, and we may include documents from both. The TEF analyzer is really the premier acoustical measurement tool in the pro audio industry, and is used by all serious consultants and sound contractors. *Smaart Pro* has also gained tremendous popularity since its introduction in 1995 because of some unique capabilities.

I've been using a TEF analyzer since 1988, and I was on staff in the TEF Products Division of Crown International for a year. My title at Crown was *TEF Products Specialist*, which means that I handled most of the technical calls for troubleshooting help, as well as the sales calls. I also demonstrated the TEF at industry trade shows, and served as an assistant in teaching the TEF workshops. I worked there until Crown sold the TEF analyzer technology to GoldLine in 1997.

**TEF** stands for *Time, Energy and Frequency*. These are the three parameters that we are interested in studying as we consider the performance of your sound system or the acoustic environment of your sanctuary. The data in the previous three graphs was gathered with a TEF analyzer using a measurement technique known as *Time Delay Spectrometry (TDS)*. The test signal is a swept sine wave.



## An Energy-Time Curve of a really bad-sounding auditorium.

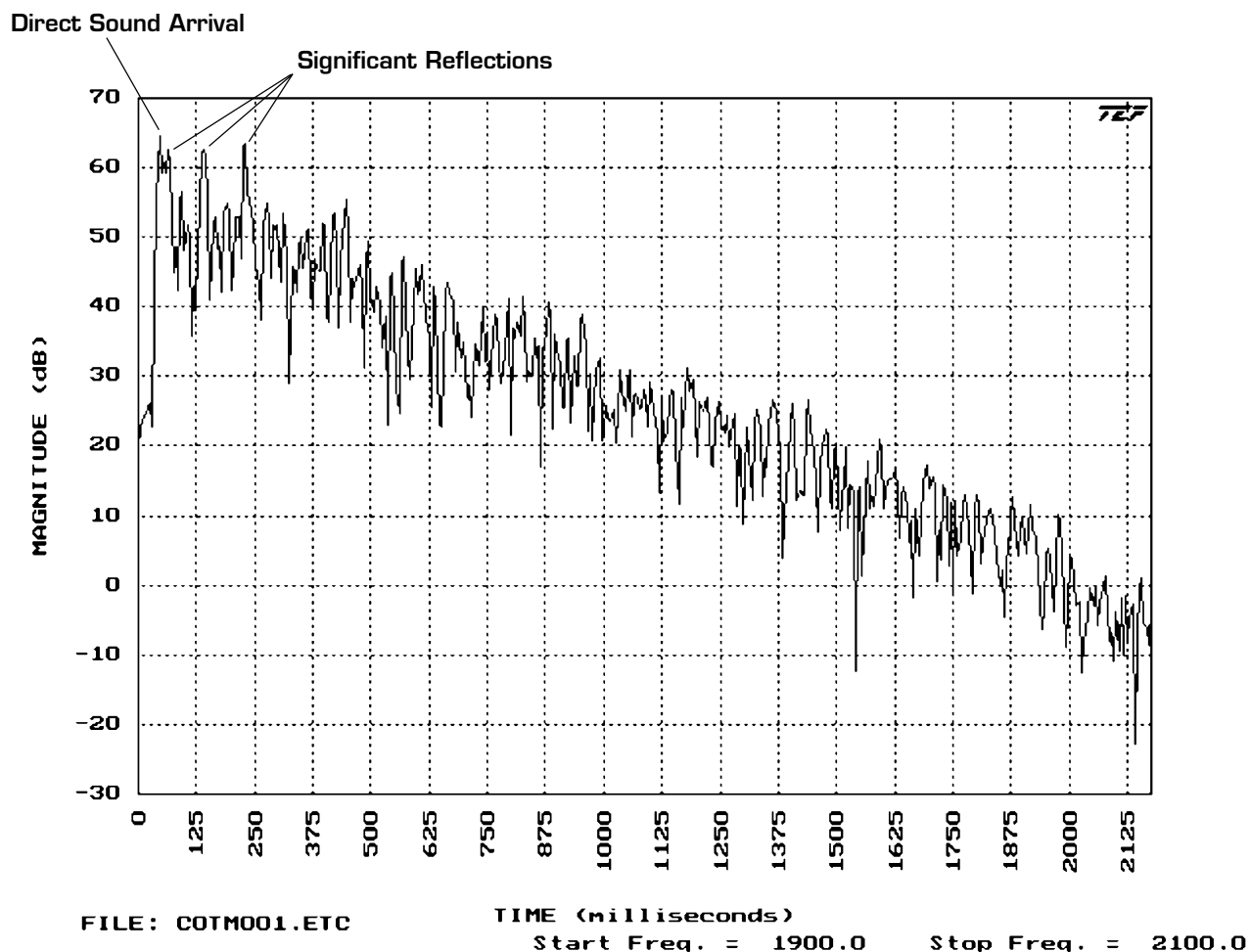

Here's a room with an interesting problem. This is the Energy-Time Curve (ETC) of a "gymnasium" with very little in the way of acoustical treatment (i.e., painted concrete block walls, sealed concrete floor, although they did have some Tectum laid flat in the ceiling). The test mic is roughly one-half of the way back into the room, a few feet to the right of the center line. Remember that we would prefer to see one clean spike at the start of the display, indicating a clean arrival of the energy from our loudspeaker. Instead, there are three spikes of almost identical amplitude! Any guesses? You've probably heard a room like this. The first spike is of course the direct sound arrival. The second tall spike is the slap off the back wall at about 100 ms later in time. The third tall spike is the arrival of the same energy, this time off the front wall yet another 100 ms later. Way cool, eh?! Talk about intelligibility problems. The %ALCONS of this room measured 12%!!! That would be funny if it weren't so pathetic. A %ALCONS of 15% or greater is considered unusable for communication. An additional modest investment in acoustical treatment is clearly warranted in this room, and would make the corporate worship experience much more enjoyable.

The first graph on page 11 is an *Energy-Time Curve*. It displays the Magnitude in decibels on the Y-axis, and Time in milliseconds on the X-axis. There is no frequency information displayed. I've marked the arrival of the Direct Sound (the energy from the loudspeaker arriving on a direct path to the test mic). All other arrivals are reflections from the ceiling, side walls, the floor, a balcony face, and so on. The art of understanding the display is in determining – usually empirically – where the significant reflections are coming from.

The second graph on page 11 displays the *Frequency versus Magnitude*, from which we can see the frequency response of the device under test. The data is gathered in a *window* of time which allows the user to zero in on the arrival of the direct energy, to the exclusion of room reflections and the reverberant field. If we were to allow those reflections to enter into the measurement, the display would likely show massive phase cancellations due to the interaction of the direct sound and those early arrivals.

Since all an equalizer can do is affect the signal going to the loudspeaker in the first place, the most logical way to voice a sound system is to first examine only the direct energy arrival. The power of the TDS (*Time Delay Spectrometry*) measurement technique used by the TEF analyzer comes from this ability to window the reflections out of the data, thereby allowing us to examine the response of just the direct sound arrival.

The TDS technique has a number of advantages over FFT or RTA measurement techniques. One such advantage is its inherent noise immunity. When we do our testing in your auditorium we will ask for quiet. That is primarily so that we can communicate and go about our work in peace. I've used TDS in auditoria with significant ambient noise, like someone using a loud vacuum cleaner, with no degradation of the test data.

Page 12 describes what we might call a *hostile* acoustic environment, and is provided here to underscore the power of the TEF analyzer for the work we will be doing for you. The gymnasium featured there is also a church sanctuary, and the church uses a contemporary style of worship with a rhythm section and vocalists. In fact I was the sound engineer for a worship night there with *Alvin Slaughter* a few years ago. Quite an experience! Imagine mixing a contemporary worship service for over 1,000 people with not only a sound system that was marginal at best, but in a room that had strong slap echoes on the order of 100 ms to 200 ms! I measured the %ALCONS in that room at 12%, and it truly was one of those rooms where you had difficulty understanding someone speaking to you standing just a few feet away.

### **Training**

As part of our complete package of designing and overseeing the installation of this sound system, TMS will provide a training seminar specifically prepared for the Church's technical ministry so that we can be assured that your new sound system will be operated properly, and that the Church is using it to its fullest potential.

It is our desire to not only design and install a great system for your church, but to also have an impact on your sound team. The fact that I have taught over 3,000 church sound team volunteers in the past several years, along with our ongoing ministry efforts through our ChurchSoundcheck Discussion Group and web site simply underscore our commitment to educate and encourage church tech support teams worldwide, including yours. We typically schedule this training period during the installation phase, preferably before your first worship service with the new sound system.

**Want to know the biggest mistake many churches  
make when installing a new sound system!?!**

**Waiting too long to hire their sound system design consultant!**

It's unfortunate when it happens, but we have seen many churches make the mistake of contracting their sound system consultant way too late in the process. One church we talked with was literally moving the pews into their new sanctuary when someone stopped to ask the question "*What are we going to do about sound?*" The solution they came up with on their own sounded miserable, and after living with the problems for a couple of

years they finally called us in to help them fix it. In the end it cost them a lot more money than it would have had they just called in a consultant to start with.

When should you hire your sound system design consultant? Preferably at the beginning of the conceptual design phase, before any major decisions have been made in regards to the room layout. That puts us in the best position to save you money.

### **Too many churches look at hiring a consultant as an expense when nothing could be further from the truth.**

In most cases we will save your church enough money to more than pay for our services simply by using our knowledge and experience to show you the right choices. And if you hire us early enough, we'll save you even more money by helping you avoid the inherent change order costs from both your architect and contractors.

*“But we’ve already got drywall going up – now what?”* If that’s where you’re at, don’t panic. You’re not too late to hire a consultant. We’ll still be able to deliver the kind of sound system you want, but you’ll really be making us earn our keep at that point. And it could mean that the installation is going to cost a bit more money as well.

For example, if the drywall is going up that usually means that getting wire from point A to point B will be more difficult, the cost of installing conduit will go up dramatically, and hanging the loudspeakers will be more of a challenge. Hopefully we can accomplish all of those objectives and still find a good listening location for the house sound engineer, find an air conditioned room for the amp racks, get clean technical power (AC) everywhere it needs to be, and so on.

Not only that, but if the drywall is already going up that often means we’re in what we call damage control in regards to the acoustics. Hopefully your architect has done a marvelous job of dealing with the acoustics issues of your facility, but the reality is that most architects have little or no training in acoustics or in sound system design as it relates to the acoustics of the room. The facility will look wonderful, but the sanctuary itself may not sound as good as you expect it to.

If that’s the case, it’s really not their fault. Traditionally the acoustic design is created by another consultant, perhaps working alongside the architect. Today it’s becoming more common for the sound system design consultant to provide the acoustics details either from someone on his staff or through a professional relationship with an independent acoustic consultant.

We know consultants who won’t even accept a job if they can’t get in on the very early stages of the building design. Indeed it is a challenge, but we enjoy a good challenge – so call us anyway. We’ll roll up our sleeves and help you get through it.

### **How many churches do you know who are on their second, third, or fourth sound system – in ten year’s time?**

How many churches do you know who are on their second, third, or fourth system – in ten years’ time!?! That doesn’t have to happen! By contracting with TMS during the concept phase, or even before the conceptual drawings are started, we can potentially save your church thousands of dollars in the long run by helping you avoid several costly mistakes in the first place, and by showing you how to install the right system that will fit your needs and your budget – the first time.

#### **Twisting Your Arm**

Obviously we want to be your consultant on this building project, or else we wouldn’t have taken the time to prepare and send this document to you. So please consider our strengths as you choose where your sound system design is going to come from. First off, you should realize that we work only as a consultant, not as a dealer. We don’t have a single box of equipment stuck in a warehouse that we need to get rid of, ‘er, sell you.

Most of the top sound system design consultants use pretty much the same computer software, and have all studied from the same textbooks and attended the same workshops. So the difference is going to be found in their individual backgrounds and experience they have to draw from.

We have been consulting with churches since 1981, and have been doing sound system designs since 1987. I think you'll find that my background brings a unique blend of experiences to bear for you. I played as a professional musician for many, many years. That experience on the other side of the microphone is incredibly valuable to me in my consulting work and to you on this design because it allows me to truly understand the needs of your musicians and worship singers. I was at the house mixing desk at Grace Church in St. Louis a few years ago during a Saturday rehearsal with the worship team when the band leader and arranger, Billy O'Dell, walked over to tell me that he was going to do an eight bar saxophone solo on the second chorus. This was the first time Billy and I had worked together so he didn't know much about my background. As he turned to go back to the stage he looked at me to ask "Do you know what '8 bars' is?" I smiled quietly and said "Yes!" The next morning, as Billy walked on stage to get ready for our Sunday morning soundcheck he found a photocopy of my Bachelor of Music degree from the University of Miami – one of the top jazz schools in the country – sitting on his music stand. He got a big laugh out of that, and to this day still smiles when he thinks about it.

Another strength that my music background affords me is my knowledge of what things should sound like. I have performed in a wide range of musical groups including stage bands, concert bands, marching bands, jazz quartets, nightclub groups, and rock & roll groups. I've played tenor sax, alto sax, flute, organ, lots of grand pianos, and electronic keyboards. When I worked with the now ancient ARP synthesizer, I studied for a month in Boston with Jim Michmerheizen, the man who wrote the owner's manual. I've performed in all sorts of venues from tiny little music rooms to outdoor concerts to 5,000 seat gymnasiums. I even sang backing vocals and lead vocals in some of those rock groups. And while I've never had time to join a church choir, I've been in hundreds of choir rehearsals both in choir rehearsal rooms and on stage, I've recorded many, many choirs, and I've successfully provided sound reinforcement hundreds of times for choirs.

All that to say, I know what most instruments and vocals are supposed to sound like because I've sat next to them listening for literally hundreds of hours as they've been played and sung. As I apply my knowledge of the technical side of recording techniques and in particular my understanding of microphones – I did get the highest grade in my class on microphones y'know – **I have over 35 years of music experience to draw from.**

Of course, even though I no longer play music professionally, I've never lost my love for music. I know a lot of church sound consultants, and I've never once seen a decent stereo system in any of their homes. So I feel somewhat approved to know that we don't have a good stereo at home either. It's as though we're so used to hearing phenomenal sound that we can't bear to listen to mediocre sound, and I guess none of us can afford to buy a phenomenal home stereo system so... Don't you feel sorry for us!?! Just kidding. And if the Christian music concerts weren't as loud as they are these days we would still attend, but I have to be a good steward of my hearing so we just don't go.

As a live sound engineer I've worked in very small churches and very large churches. The greatest single-day brain switch for me was to mix the Worship International team with Marty Nystrom leading worship in a 100 seat prison chapel northeast of Orlando, Florida with a twelve channel console (of which 4 channels weren't working), then pack up and drive over to Lakeland and setup to mix in the 10,000 seat Carpenter's Home Church that evening on a pair of 32 input consoles, with a separate monitor mix desk.

I learned many of my recording techniques from my teacher at the University of Miami, *Bill Porter*. Bill was Elvis Presley's engineer for many years, and recorded all of the early Everly Brothers' hit songs, Roy Orbison's *Pretty Woman*, Boots Randolph's *Yakety Sax*, and did a lot of work for Chet Atkins. In fact I came back to the spring semester a week late one year, and had trouble finding a place to stay. Bill offered to let me stay on his couch "for the weekend". I ended up living at his place for almost the whole semester.

---

## DESIGNING YOUR NEW SOUND SYSTEM

This was back in the days before I was saved, and Sunday mornings would often consist of listening to old gospel albums that Bill had recorded. What an experience that was, to be able to pick his brain about how he recorded this and that, and how he got those sounds. I thank God to this day for that opportunity. Many would have given anything to have had that opportunity, but it just happened to me. Obviously God was looking out for me, preparing me for this day even when I was wandering around searching for Him.

That experience and God's hand on my life brought me into situations where I got to record the albums that got Tom Brooks noticed by *Integrity Music*. Integrity had released one album of their *Hosanna* series when they heard what we were doing at Grace Church. They liked it so much that a few of their early releases were actually albums we had recorded at Grace. All we did was overdub Kent Henry as the worship leader, and remix the project for Integrity. The rest, as they say, is history.

After leaving Grace a few years later I worked in Tom's home studio for a season. Tom became the Senior Producer for Integrity, and my wife and I almost moved to California when Tom moved his family and studio out there. In fact we spent a week looking at real estate there. But for a number of reasons we chose to stay in the midwest. And that's good, because had I moved out there I probably wouldn't be working as a consultant today.

As a church staff member for eight years, I learned how to manage both my engineering staff and a group of wonderful volunteers. As I mentioned earlier, I know from firsthand experience that the audio ministry is not the only group asking the pastor for money. I've learned to appreciate the big picture. That experience has proven absolutely invaluable to me both in teaching workshops on church sound as well as consulting with churches on everything from getting a better sound from the equipment they've already got to work with, to designing a brand new sound system from the ground up.

In fact it was during a season of prayer at Grace in 1986 that God planted this desire in my heart to reach out to other church tech staff and volunteers. And we've invested thousands of hours and tens of thousands of dollars doing just that. I remember the exact spot in the balcony where I was praying when God put this desire in my heart. And in spite of our efforts to run away from it, God won't let us go. Believe me – we've tried. We finally figured out that He's bigger than us, and submitted our life fully to what He wants us to do. All you need to do is spend a single day reading the email that comes through our *ChurchSoundcheck Discussion Group* that we started and you'll see the fruit immediately.

Okay, is that enough arm twisting? Look, we're going to have a great time working together on this project. I'll personally deliver a phenomenal sound system design influenced solely by your needs. So don't put off this decision any longer. Just give us a call and we'll get started on your project. Every day you wait means more money we could have saved you.

Please don't hesitate to contact us if you have any questions at all about the contents of this document, or regarding any phase of the design. We look forward to hearing from you in the near future.

Blessings in Christ!  
Taipale Media Systems, Inc.



Curt Taipale  
President

P.S. For the adventurous reader, I've included some additional thoughts on the following pages. One topic worth discussing is where to put the house mixing desk. And I've taken a moment to briefly describe the process that I'll go through in preparing the acoustic model of your sanctuary. Also enclosed is a copy of my resume for your perusal, along with a list of people you can ask about my past design work. Say hello for me.

## Where Should the House Mixing Desk Go?

The issue of where to place the house mixing console often brings up an awkward debate between the church sound team, the building committee and the senior pastor. It could be that the sound team has been mixing from a compromised listening location for some time, and they look at building a new facility as their opportunity to finally get the location they need to do the job the pastor and music minister have been asking them to do.

By comparison, if it were physically possible many senior pastors would prefer that no sound equipment be visible anywhere in the auditorium. The church administrator may be looking at the cost per square foot of this building project, and finds it difficult to justify giving up anywhere from ten to thirty prime listening seats for the sound booth. The individuals in the sound committee find themselves sitting in the middle of this debate, but let's face it – they often bring their own preferences to the table as well.

So who's right? Obviously, each argument has its own merit. The type of worship service you have can have a bearing on the location of the sound booth as well. The key is the number of microphones in use and if any true mixing needs to be done of those elements. A worship service with a single open microphone is so simple that one could literally put the controls in a nearby closet and be fine. The moment you add that second microphone for anything – choir, piano, et al – you'll need to consider the need for the mixing process and a suitable location for the sound mixer to hear what's going on.

Can we get one thing straight right off the bat? If you're serious about delivering a good musical mix, there are two awkward locations for the sound booth that a church should do their best to avoid: *in an enclosed booth with an opening to the sanctuary cut into the wall*, or worse yet, *in a booth located behind a glass window*. Neither of these locations will allow your sound mixing engineer to hear what they need to deliver a good mix.

By the way, when I use the term *sound booth* I'm speaking in general terms of the area in which the house mixing desk and related outboard equipment are sectioned off. I don't at all mean an enclosed room with an opening cut into a wall, or worse yet – behind a window. At most, the walls that section off the sound booth should not rise above the height of the mixing console itself.

Don't do what this church did. Their main sanctuary is roughly 50 ft wide by 50 ft deep. The stage is 2 ft high, and goes back an additional 15 ft. The roof has a pitch of 12:1 and comes to roughly 15 ft at the center, directly above the center aisle. The general lighting in the sanctuary consists of large hanging globes, roughly 2 ft in diameter, and hanging about 3 ft below the ceiling. There are three rows of lights, with four lights each, and one of those is directly down the center aisle.

When the church debated about how to install their sound equipment, they decided that it was important to hide the mixing console and related gear. Someone looked at the back wall of the auditorium and decided that if they were to cut an opening at the very top of the ceiling, that they could create a room above the main entrance to the sanctuary and put the sound equipment there.

They lived with this horrendous situation for about the first year and then eventually built a sound booth in the left rear corner of the main floor and moved the equipment there. The church called me a couple of years after they had moved into this building and invited me over to help them straighten out some of their remaining sound problems. As we talked, the sound engineer asked me if I'd be interested in seeing where the sound booth used to be. Well, you wouldn't have to ask me that question twice! So picture this. He leads me into the church offices, through the pastor's study!, opens up the pastor's coat closet, and starts to make his way up a wooden ladder that has been built into the side of the closet wall.

We manage to shimmy up this ladder, at which point he tells me to be sure and bend over so I don't hit my head. By now I feel like I'm going into tree fort, but I dutifully bend over, waddle into the room ahead and then straighten up and start giggling uncontrollably at what he used to face every Sunday morning! Standing in this room barely big enough for one or two people, I can look through the A-shaped opening (cut into the back wall as mentioned

earlier) out into the auditorium. I can't actually *see* the center of the stage, only the extreme left and right sides, because the globe lights block the line of sight entirely.

Along the wall to my left is a shelf where the mixing console and tape decks used to live. As the church's sound engineer describes how bad this situation used to be, he illustrates that in order to hear anything of the sound system he literally had to turn himself sideways and lean out the opening to get his ears actually into the auditorium. Can you imagine how frustrating that must have been for that sound team? I shouldn't say that – maybe your sound team is in a similar predicament.

I have a dozen stories of poor mixing locations like that. In fact one day I'm going to write an article called *The Worst Mixing Locations on the Planet*. Now, to any sound mixer it's just common sense that the mixing desk should be located at a spot in the auditorium that will allow them to (1) clearly hear the direct sound from the loudspeaker system, (2) have an unobstructed view of the main platform, and (3) clearly hear the congregation as they worship. This hole in the wall offered none of the above. The sound team had tried to explain this problem to the church leadership during the installation, but they refused to accept their comments as truth.

I can't fault that church's leadership entirely for making such a costly decision. What a person holds as true is based on their knowledge. They simply didn't have the knowledge they needed to make an informed decision. And at the risk of boring you or dwelling on the obvious here, I'm simply trying to make sure that you're armed with the knowledge you need to make an informed decision on your current needs. Take this advice from someone who has mixed from every imaginable house mix location in over a hundred different church sanctuaries, and who cares enough for your church and your sound team to fight for what is right.

So why is mixing from a hole in the wall such a bad thing? First off, the sound mixer doesn't get a true representation of what the congregation is hearing. The average member of the congregation simply enjoys listening to the music as a whole. If they can't hear or understand the words being sung by the worship leader, or if the sound is too loud overall, they'll know it and may even say something about it to an usher.

On the other hand, sound mixers listen to the worship music very analytically. They tear it apart in their mind and make a judgement about each component. They listen to hear if the vocal is too loud or loud enough as it relates to the overall mix. They listen to the timbre and quality of each sound and make a decision on whether or not it could be improved with a slight adjustment to the channel equalization. They listen for how the effects devices like reverb are being used and if a certain element needs more or less of the effect, and so on. They also listen for how loud the congregation is singing, and then use that as a gauge for how loud to run the sound system. Too soft and the congregation won't really enter into worship. Too loud and they'll lose the sense of corporate worship, and probably start complaining. This process is fairly involved, and yet each decision takes only the blink of an eye.

The balcony is another less than optimum location for the house mixing desk. Again, if you were mixing the sound, where would you best be able to make decisions on both the inner balance of voices and instruments that your congregation hears, and the balance between how loud the sound system is relative to how strong the congregation is singing? Your answer should be "where the ears of the congregation are – in the main seating area on the main floor of the sanctuary!"

If the "house" mixing console is not positioned so that the operator can clearly hear both the sound system and the congregation in their own setting, then his/her mix will never be more than an interpretive mix at best. For example, let's say that the house mix position is in the balcony. The sound system could be too loud on the main floor and your engineer won't know it.

As I mentioned earlier, one thing you'll find when the sound system gets too loud is that the congregation starts to lose a sense of corporate worship. That sense of corporate worship is one powerful difference that makes music in your church unique from other types of live music, and it brings a tremendous sense of life to the worship experience. Running the sound system too loud robs the congregation of their right to that experience. No amount of running down from the balcony to hear what it sounds like on the main floor will ever make up for simply placing the console where it should be in the first place.

If placing the house mix position on the main floor is unlikely, what are your options? I can't make a blanket statement that the console should never be in the balcony because in some cases it does work. If you're forced into putting the house console in the balcony, you may be able to improve the situation by adding a dedicated house loudspeaker out in front and slightly above the engineer's head that is delayed, equalized and level-matched to represent a listener's seat on the main floor of the sanctuary. The engineer won't hear the congregation, but at least he will hear the mix okay.

Another point to consider is to not place the console exactly on the centerline of the room. As the sound from your speaker system interacts with the acoustics of your sanctuary, there will be points in the room where the sound energy cancels. Try setting up a sine wave oscillator at, for example, 100 Hz, feed it over the sound system and then walk around the room listening for areas in which the sound cancels. It depends on the arrangement of your auditorium as well as the location of your main speakers, but since most church sanctuaries are fairly symmetrical, it's entirely possible that you'll have a significant cancellation in the center of the room. At low frequencies this null point could be physically quite wide! Therefore, it is entirely possible that a house desk placed at the center of the balcony, for example, could *miss* some of the low frequencies.

Given that situation, a beginning sound mixer's natural reaction would be to push the bass by adding more low frequency EQ than is needed, and/or by mixing the bass guitar and possibly other instruments louder than is needed. The only way to know if the low end is right is to walk away from the sound booth and listen in other areas of the room. While the engineer is away from the console, the mix could easily suffer. Worse yet, they could miss mic cues entirely if they chose the wrong moment to walk around and check their mix. That's no fun for the worship team, for the congregation, and it's especially no fun for the house engineer.

And what if the loudspeaker system isn't doing its job in the balcony, leaving the sound at the house desk *dull* due to a lack of high frequencies? The task becomes one of an interpretive mix – that is to say, the sound mixing engineer has to compare the difference between what the congregation is hearing on the main floor and what he is hearing at the house desk, and then make adjustments accordingly. The unseasoned engineer would simply crank up the high frequencies on the channel EQ to make the mix sound like he wants it to at the house desk. But that will make for a very harsh sound for the congregation.

Or what about this!?! I was visiting a church near us just recently and noticed that the house mix desk was placed in an awkward location. The rear seating area is raked up at a steep angle, and the production booth is located in what could be considered a balcony location. Standing at the mix desk, your ears are right on the centerline of the room, and get this – there are **no loudspeakers** aiming even near this area! There are two loudspeakers that aim into the seating areas adjacent to the production booth, so not only can he not hear a loudspeaker directly, but he's exactly in the middle between two distant loudspeakers. Sounds like a perfect invitation for phase cancellations, doesn't it!?! And indeed it is.

As I mentioned earlier, another popular choice of churches is to place the console within an opening in the back wall of the sanctuary, and this solution generally forces a serious handicap on the engineer. The integrity of the sound heard inside that cavity can vary as much as 10 dB to 20 dB both in high frequency response and in overall level as compared with that of a prime seating location on the main floor. And since the opening is, in effect, a room of its own, it can also present its own acoustic imprint on the sound. In a setting like this, it is highly unlikely that the sound heard by the engineer is anywhere close to that heard by the congregation, not only in frequency response but also in loudness. Mixing in that environment is like trying to drive down the highway with your windshield frosted over. Take a look at the TEF curves on the next page and you'll see what I'm talking about. The top curve is the frequency response of the sound system on the main floor. It's not performing very well to begin with, but look how poor the response is at the house desk in the booth. It's 10 dB softer than what the congregation hears, and the high end is obviously lacking. This typical booth has an opening to the auditorium of roughly 15 ft wide by 5 ft high – a seemingly generous opening.

One more location to avoid – please never ever put the house mix position in a room behind a glass window, or in a closet somewhere! I've seen some awful mixing locations, but one of the worst was in a church in Singapore.

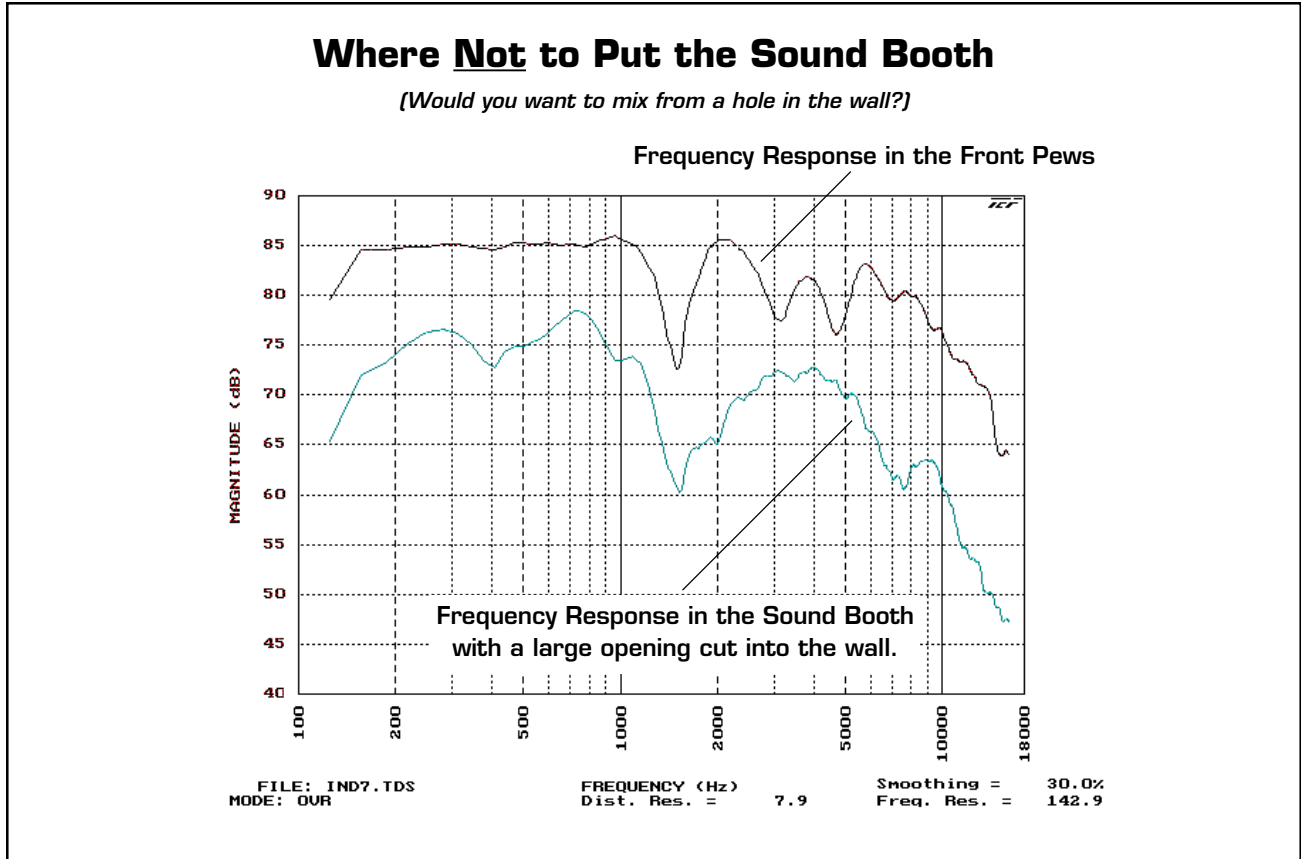

The church sound engineer, who also happened to be the church administrator, was totally enclosed in a curtained room with dark glass walls. He had a tiny window, roughly eight inches high by twelve inches wide, that he could open to *hear* what was going on in the sanctuary. As is common in this type of booth, he had a microphone suspended out in the sanctuary that fed a pair of speakers so he could hear a representation of the sound out there. Also, he couldn't actually see the stage clearly from this location, so he had a remote controlled camera positioned on a column up high and in front of the stage that fed a small video monitor sitting over the house desk. I was glad that I was there to teach, not mix.

Here's a brief checklist to help you properly locate the house mix position:

- Can the engineer visually see down the throat of a high frequency horn aimed at that location?*
- Can the engineer clearly observe all that is happening on stage?*
- Is the engineer physically close enough to the main body of the congregation to share in their worship experience, and therefore to include the congregation's singing as part of his/her mix?*
- Is the area above or to the sides of the location free of all acoustical obstructions within 10 feet?*
- Is the frequency response and sound pressure level at the house mix position within  $\pm 3$  dB of the frequency response and SPL measured at a prime location in the main seating section?*

The bottom line – if the mix ain't happening, don't shoot the engineer. It may not be his fault. Instead we encourage you to try to be less concerned about hiding the sound equipment and the engineer, and more ready to equip the team to do the job you've asked them to do.

Let us help you decide on a location for the house mixing desk that will accommodate the necessary technical needs of your production team without becoming a visual distraction to the congregation.

## A Brief Look at Modeling the Acoustics of Your Sanctuary

As I mentioned earlier in this report, modeling your auditorium with the EASE software can take anywhere from one long day to several days. It depends on how complex the architecture of your room is. I start with the floor plan from your architect and an architectural rule, measuring each point and then transferring that data – point by point – to the computer model.

Each point or *vertex* requires an X, Y and Z coordinate. The *X coordinate* is the distance to the left or right of the centerline – a line that goes from front to back right through the center of the room, often right through the pulpit location. The *Y coordinate* is the distance from the back wall of the stage toward and through the audience. And the *Z coordinate* is the height of each vertex above the finished floor.

By the way, when I speak of the front or back of the sanctuary, I consider the *front* to be the rear wall of the stage – basically the walls that the congregation is facing during the worship service. The *back* of the auditorium is the wall behind the congregation. And while we're at it, *House Left* is to the left of the centerline as you stand in the auditorium facing the stage. *Stage Right* is to the right of the centerline as you stand on stage facing the audience seating.

Here's a look at how I'll approach doing the acoustical model for your sanctuary. For example, let's say that you have a simple A-frame auditorium that measures 40 ft wide by 78 ft deep, and the ceiling height is 33 ft. There are two main seating sections, each 11 ft wide separated by a 6 ft aisle. The platform or stage is 17 ft deep including the front steps, leaving a 6 ft buffer between the front lip of the stage and the first row of seats.

In this example, one of my first steps is to mark the outline of the seating sections. So in this case I would simply enter a vertex of  $X = -3.0, Y = -23.0, Z = 0$ . That vertex is labeled *P1*, and it marks the inside front corner of the left seating section. The next vertex I would enter is the inside rear corner of the same seating section, so  $P2 = (-3.0, -72.0, 0)$ . The outside rear corner is  $P3 = (-14.0, -72.0, 0)$ , and the outside front corner is  $P4 = (-14.0, -23.0, 0)$ . Once the seating areas are marked off, I would add the traffic areas.

### 1. I'll start with the Audience Areas

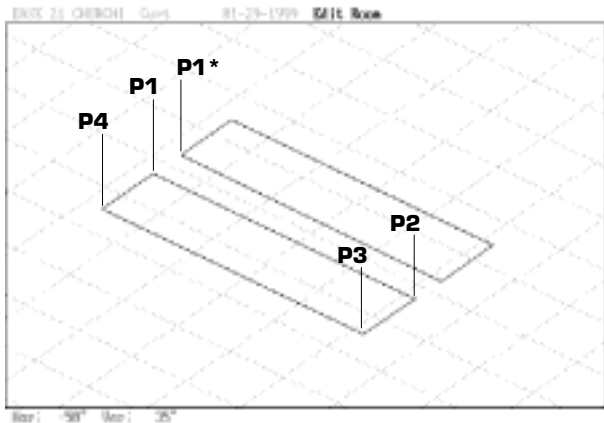

### 2. Then add the Walkways

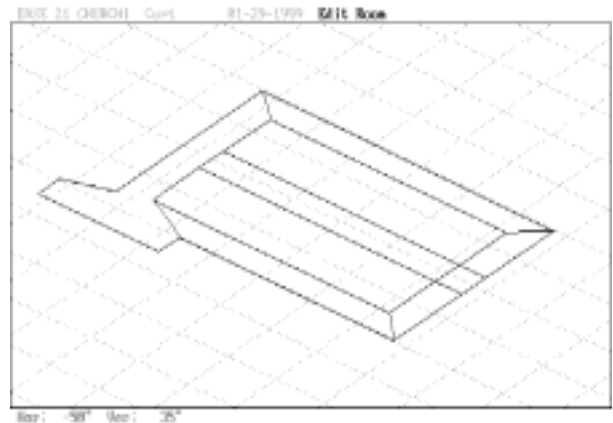

By the way, if I have *symmetry* turned on, the computer will automatically mirror each vertex that I enter. For example, the moment I enter the vertex *P1*, a mirror-image vertex, *P1\**, will be placed at  $X = +3.0, Y = -25.0, Z = 0$ . Notice that this leaves a 6 ft aisle between the left and right seating sections. The software *knows* that each vertex I place on the left side of the auditorium is to be duplicated on the right side of the centerline. That's great because, IF your sanctuary is symmetrical, I'll only need to draw one-half of it and the computer will calculate the rest. If your sanctuary is asymmetrical, like the one in this example, then I'll turn symmetry off and enter all of the vertices manually. The process is no different. It just takes a little longer.

### 3. Next, I'll include the Platform

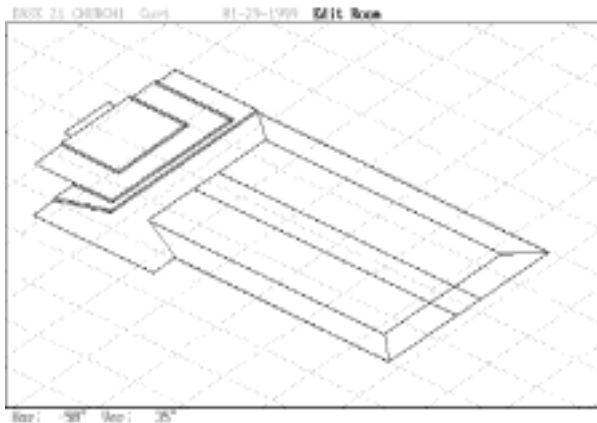

### 4. Put up the Side Walls

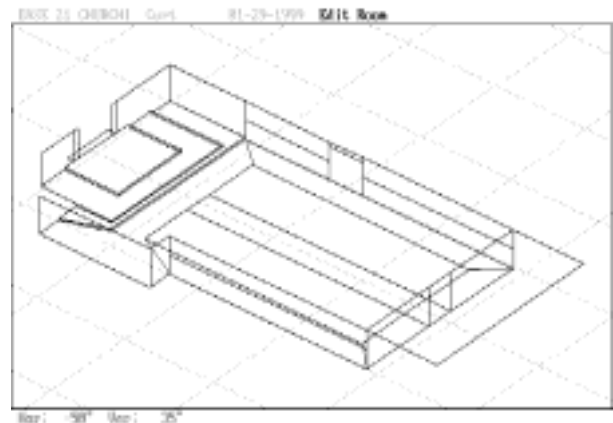

### 5. Then add the End Walls

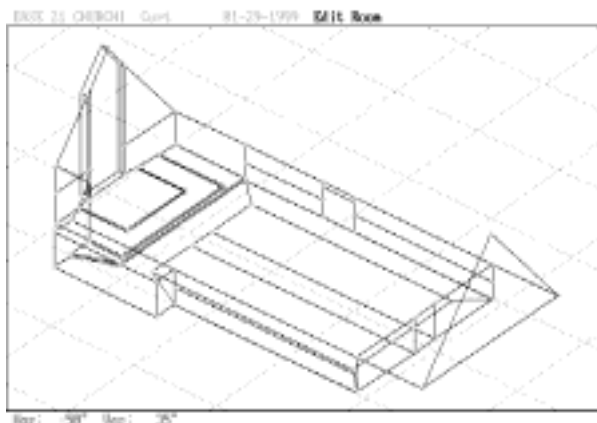

### 6. And here's the Finished Model

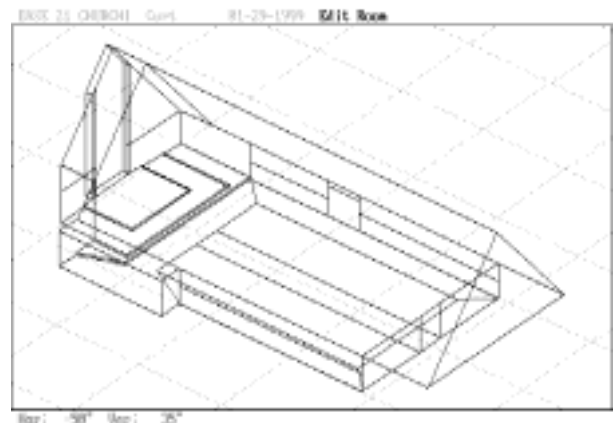

As soon as I have a handful of vertices in place, I'll start to include the *faces*. I'll use my mouse to graphically connect the four points that make up that left seating section mentioned above, and then assign an acoustical material to that face like *people in padded pews* for example. I have a huge database of acoustic materials from which to choose. Everything from carpet glued onto a concrete floor, or 5/8-inch sheetrock, to 2-inch absorptive panels or sprayed-on cellulose fibers. There are over *150 materials* in the database.

Speaking of databases, the loudspeaker database that I use has products from 39 manufacturers, each with several loudspeakers on file. In all there are more than *875 loudspeakers* to choose from!

Of course there's much more to it than this, but can you see why building a computer model might take quite a bit of time? Some of my simplest room models have involved around 80 vertices and 60 faces, and yet I've done more architecturally complex sanctuaries that required more like 800 vertices and 600 faces. And if the room has a raked (sloped) floor, making everything fall into place starts to get interesting. The example I've used here has a flat floor with 88 vertices and 57 faces,

As I mentioned earlier, developing an acoustical model of a church sanctuary combines art with science. There comes a point where excruciating detail won't yield any significant improvement in the accuracy of the model, and yet that extra detail will require significantly longer calculation times in later post-processing of the data. After working with EASE since 1993, and doing well over 100 acoustical models of church sanctuaries, I've learned when to draw that line.

Please don't hesitate to ask any questions about preparing the model for your sanctuary. We're ready to start when you are!

## **Curtis P. Taipale**

1201 Aberdeen Dr. • Allen, TX. 75002  
(972) 747-8083 • <ctaipale@aol.com>

### **Objective**

To do everything within our power to help you as well as your worship team, technical support team and church staff to take back your dream of achieving technical excellence in every worship service!

### **Work Experience**

#### **Director of Engineering & Design – dB Acoustics**

**1997 – 1998**

My job was to design sound systems and acoustic systems for churches, and to assist the team by preparing engineering drawings to guide their installations.

#### **TEF Product Specialist – Crown International**

**1996 – 1997**

My responsibilities included sales of TEF hardware and software, as well as creating sales letters and marketing ideas for TEF Products. I was the primary technical support person for existing TEF customers, and I designed all customer support materials. I also created the workbook for the TEF Class and orchestrated all aspects of and served as the facilitator for those classes.

#### **President – Taipale Media Systems, Inc.**

**1981 – Present**

I founded Taipale Audio Services in 1981, and then incorporated as Taipale Media Systems in 1987. We have dedicated this small company to communicating technical excellence to the church. Our business includes audio consulting, sound system design and installation, technical writing, and education. A key part of our business from 1992 through 1995 was working with Worship International. I traveled all over the U.S. with their music team, handling their sound engineering needs and teaching classes in the basics of sound system operation for the church. I worked in over 60 churches during those three years.

#### **Founder & Instructor for Soundcheck Workshops**

**1987 – Present**

With our primary marketing effort directed toward the church community, I have trained over 3,000 church music pastors, technical staff and volunteer sound technicians. Soundcheck Workshops was formed to educate the church in the basics of sound reinforcement. We have also hired other instructors to teach courses in related disciplines as part of our larger-scale church production conferences.

#### **Founder, Publisher & Editor of Soundcheck® Magazine**

**1987 – 1990**

I was in charge of all functions from writing to layout to promotion. We published sixteen issues, most of which were 48 pages. Merged with the Psalmist Magazine in the fall of 1990. However, this magazine continues to be available today via the World Wide Web at <<http://www.churchsoundcheck.com>>. Our **ChurchSoundcheck Discussion Group** unites members from all over the US and from several foreign countries with the common goal of achieving technical excellence in our local churches.

#### **Director of Audio – Grace Church, St. Louis**

**1991 – 1994**

I served as Director of Audio from 1982 through 1987, and then again from 1991 through 1994, for a total of eight years on staff. I was in charge of all audio operations for their 5,000 seat church auditorium and 24 track recording studio, and oversaw the design, wiring and function of all thirteen sound systems on site. I served as chief sound reinforcement and recording engineer for all in-house audio productions and recordings, plus headed and trained a volunteer staff of fifteen people and two full-time assistant engineers.

#### **Recording Engineer – New Earth Productions, Inc.**

**1980 – 1988**

I worked as chief recording engineer on a variety of albums, singles, radio jingles, and A/V projects, including album projects for Integrity's Hosanna! Music line, and A/V projects for Busch Creative. I also designed and installed all wiring connections for NEP's 24 track recording studio.

---

## Resume for Curt Taipale

---

### Adjunct Faculty – Webster University

1985 – 1988

Here I taught Audio I, Audio II and Audio Engineering classes for several semesters. I also taught a special class on Sound Reinforcement, and was in charge of their campus recording studio operations.

### Chief Engineer – KBK/Earth City Sound Studios

1980 – 1982

Designed by John Storyk and built by Rudy Bruer, this studio was a first class recording facility by anyone's standards. I was in charge of all recording and maintenance procedures.

### Professional Musician

1968 – 1980

Toured with a handful of rock & roll groups. Played keyboards and saxophone.

## Technical Writing Experience

Yamaha's Guide to Sound Systems for Worship

(Chapters 1, 2 & 13) Published in 1990 by Hal Leonard Publishing.

Contributing Author

How to Start, Train & Operate an Audio Ministry

Published in 1989 by Taipale Media Systems, Inc.

Author

In addition, I have authored over 50 articles that have been published in magazines targeted to reach church music pastors, technical staff and volunteer sound teams including *Your Church*, *Technologies for Worship*, *Worship Leader*, *Creator*, *Psalmist*, and *Soundcheck*.

## Education

University of Miami, Bachelor of Music

Major – Music Engineering Technology; Minor – Electrical Engineering

Under the instruction of Bill Porter and Ken Pohlmann

Applied Instrument – Classical Piano • Additional Jazz Piano Studies

Graduated 1980

Drury College, Springfield, MO

Studies in music and liberal arts.

1975 – 1976

Parkwood High School

Played saxophone with concert band and jazz band.

Graduated 1969

## Special Technical Studies

MediaMatrix Workshop • Peavey • Douglas, Harshbarger & Valentine

1998

TEF Classes • Pat Brown and Blair McNair

1995, 1996 & 1997

Syn-Aud-Con Advanced Seminar • Pat Brown

1996 & 1997

EASE Training Seminar • Ron Sauro and Vance Breshears

1994, 1996 & 1997

Horns II • Syn-Aud-Con Workshop

1995

Syn-Aud-Con Concert Sound Reinforcement Seminar

1991

Bose Sound System Design Seminar

1990

Synergetic Audio Concepts (*four time graduate of their basic seminar*)

1981 – 1989, & 1997

Boston School of Electronic Music

1976

Institute of Audio Research

1976

Modern Recording Techniques

1975

---

**Sound System & Acoustic Designs**

Emmanuel Pentecostal Church • Mesquite, TX • Acoustic Model & System Design • Project in Progress  
Tri-City Christian Center • Canton, MI • Sound System & Acoustic Design • Project in Progress  
Victory Baptist Church • Stone Mountain, GA • Acoustic Model • Project in Progress  
Living Bread Fellowship • Washington, MO • Sound System & Acoustic Design • Project in Progress  
New Birth Missionary Baptist Church • Atlanta, GA • Acoustic Model • Completed June 2000  
Countryside Covenant Church • McPherson, KS • Acoustic Model • Completed June 2000  
Victor Valley Christian Church • Hesperia, CA • Sound System & Acoustic Design • Completed June 2000  
Friendship Baptist Church • Toledo, OH • Acoustic Design • Completed May 2000  
Rhema Christian Fellowship • Olean, NY • Sound System & Acoustic Design • Project in Progress  
Cornerstone Church • Grove, OK • Sound System & Acoustic Design • Completed September 1999  
Eagle's Landing FBC • McDonough, GA • Acoustic Model • Completed June 1999  
New Covenant Christian Church • Lithonia, GA • Acoustic Design • Completed May 1999  
Turner Chapel A.M.E. Church • Atlanta, GA • Acoustic Design • Completed May 1999  
Jackson Memorial Baptist Church • Atlanta, GA • Acoustic Design • Completed May 1999  
Sherwood Baptist Church • Albany, GA • Acoustic Model • Completed March 1999  
Southlake Church of Christ • Southlake, TX • Acoustic Design • Completed February 1999  
First Redeemer Church • Cumming, GA • Acoustic Model • Completed December 1998  
Free Methodist Church • Greenville, IL • Completed October 1997  
St. Louis Family Church • Chesterfield, MO • Completed November 1997  
The Church at Andover • Louisville, KY • Completed January 1997  
St. Louis Family Church • Chesterfield, MO • Completed November 1996  
First Assembly of God • Kalamazoo, MI • Completed February 1996  
Church on the North Coast • Lorain, OH • Completed August 1995  
New Creation Church • Longmont, CO • Completed August 1995  
New Creation Church • Longmont, CO • Completed November 1994  
River of Life • Cedar Rapids, IA • Completed August 1994  
Life Christian Center • St. Louis, MO • Completed July 1994  
First Christian Church • Aberdeen, MS • Completed October 1993  
St. Louis Family Church • Chesterfield, MO • Completed March 1993  
The Life Church • San Juan Capistrano, CA • Completed February 1993  
First Assembly of God • Wood River, IL • Completed November 1992  
Broadway Baptist Church • Kansas City, KS • Completed April 1992  
Church of Christ • Havana, IL • Completed October 1991  
First Baptist Church • Greenville, IL • Completed September 1990  
Living Bread Fellowship • Washington, MO • Completed February 1990  
First Baptist Church • Morristown, TN • Sound System Design • Design Completed April 1998  
First Baptist Church • Blairsville, GA • Sound System Design • Design Completed April 1998  
Riverbend Baptist Church • Gainesville, GA • Engineering Work • Completed March 1998

---

## Church Sound System Design References

---

**Rod Cole • Head of Sound Team** (volunteer)  
Victor Valley Christian Church • Hesperia, CA  
New sound system completed in June 2000. Self-Installed.  
Church: 760-244-4448 / Home: 760-241-9501  
Email: <connecttoo@aol.com>

---

**Mark Napier • Head of Sound Team** (volunteer)  
Cornerstone Church • Grove, OK  
New sound system completed in September 1999. Design/Build.  
Work: 918-787-6663 / Church: 918-786-6164  
Email: <mnapier@greencis.net>

---

**Duane Green • Head of Sound Team** (volunteer)  
First Baptist Church • The Colony, TX  
New sound system completed in April 2000. Self-Installed.  
Church: 972-625-1322 / Home: 972-625-2382  
Email: <greend4@aetna.com>

---

**Warren Pettit**  
Free Methodist Church • Greenville, IL  
New sound system completed in October 1997. Self-Installed.  
Work: 618-664-1840, ext 4341 / Home: 618-664-4351  
Email: <wpettit@greenville.edu>

---

**Paul Tassler • Programming Director**  
St. Louis Family Church • Chesterfield, MO  
New sound system completed in November 1996. Self-Installed.  
System expanded during November 1997 renovation.  
Church: 636-532-3446

---

**Bob Walker • Minister of Music**  
First Assembly of God • Kalamazoo, MI  
New sound system completed in February 1996. Design/Build.  
Church: 616-329-1977  
Email: <PastorBob@firstassembly.org>

---

**Lee Anderson • Music Pastor**  
Church on the North Coast • Lorain, OH  
New sound system completed in August 1995. Design/Build.  
Church: 440-960-1100

---

**Ronnie Brumley • Music Pastor**  
New Creation Church • Longmont, CO  
New sound system completed in November 1994. Design/Build.  
Foyer system and choir monitor added in August 1995.  
Church: 303-776-4225

---

---

---

# Designing Your New Church Sound System

---

---

## **Taipale Media Systems, Inc.**

1201 Aberdeen Dr. • Allen, TX. 75002

Voice: (888) 547-1727 • FAX: (972) 747-8084

Email: <curt@churchsoundcheck.com>

Web Site: <http://www.churchsoundcheck.com>